



# EXTENDABLE CHOKER ARCH

# 2400 SOFT TRACK SKIDDER



The KMC SOFT TRACK SKIDDER has Three MAJOR Design Advantages over Conventional Ground Skidding

### BALANCED WEIGHT DISTRIBUTION

Because of the forward mounting of the power train, and the skidder's ability to carry the log load well forward on the machine, the combined weight of the vehicle and its payload is spread over the entire length of the tracks.

### TORSION BAR SPRUNG SUSPENSION

Ten torsion bars attached individually to roadarms provide the sprung suspension. Each set of road wheels can move up and down independently, thereby allowing the tracks to conform to uneven surfaces.

### HIGH SPEED STEEL TRACK (HSST)

Cast Steel track pads, connected with patented rubber-bushed steel pins, permit track flexibility while preventing metal-to-metal wear and track contamination from

The KMC 2400 is designed to haul medium and large timber in virtually any operating conditions. The choker arch extends hydraulically toward the load, then retracts as the load is winched in, lifting the butts onto the rear deck of the machine, close to its center of gravity. This eliminates butt dozing, and aids in balancing the weight distribution which results in better traction, higher speeds, greater productivity and consistent low Dynamic ground pressure.

### KEY OPERATIONAL DATA

Maximum Payload: 35,000lbs (15,873kg)  
Maximum Weight on Vehicle: 21,000lbs (9,524kg)  
Gross Vehicle Weight: 30,700lbs (13,923kg)

Ground Pressure: 5.29psi at 0" soil penetration  
4.78psi at 6" soil penetration

### SPECIAL OPTION

Pin-On Grapple Attachment

### PRIME APPLICATIONS

- Steep Slopes
- Wet or Boggy Areas
- Sensitive Soils
- Big Wood
- Long Skids
- Special Management Zones

### INTEGRATES WELL WITH

- Cable Yarders
- Helicopter Logging

**KOOTENAY  
MANUFACTURING  
CO. LTD.**

KMC Hotline: 1 - 800 - KMC - 5303



Printed  
in  
Canada

606 Lakeside Dr., Nelson, B.C., Canada V1L 5S7 Ph. (250) 352-5303 / Fax (250) 352-5302



## 2000 SERIES SPECIFICATIONS



### POWER TRAIN

Engine: Standard - Cummins 6BTA5.9 174HP  
 Option - John Deere 6068T 185HP  
 (for John Deere Dealers)

Transmission: Clark HR28420-7 4 Speed Powershift

Differential: Controlled Steering Type

Final Drive: Planetary

Fuel Tank Capacity: 45 to 70 gal (205 to 318L)

### BRAKES - 3 SYSTEMS

Service: Hydraulic, oil cooled multiple disk in transmission

Differential: Hydraulic steering levers, when pulled back simultaneously

Parking: Manual, transmission mounted

### GAUGES AND INSTRUMENTS

Engine: rpm, hours, coolant temperature, oil pressure

Transmission: oil temperature, oil pressure

Differential: oil temperature

Battery: amp meter

Other: low fuel, parking brake

### BLADE OPTIONS

Standard decking

4 way tilt

6 way tilt/angle - brush rake or snow plow only

### CAB OPTIONS

Screened, half doors

Screened, full doors

Fully Enclosed, sound suppressed

### SEAT OPTIONS

Standard bucket type

Suspension, swivel, high back c/w joystick controls

### UNDERCARRIAGE

Suspension: Torsion Bar Sprung,  
 independent road wheels

Road Wheels: 100% Cast Steel, 5 sets of Dual Wheels per side, 24" (610mm) diameter

Track: Manganese Alloy Cast Steel

with Rubber - Bushed Pins, 22" (559mm) wide

Sprockets: Hardox 400 steel

### MAXIMUM TRAVEL SPEED

1st gear: 2.2 mph/3.54 kph

2nd gear: 4.6 mph/7.40 kph

3rd gear: 8.0 mph/12.87 kph

4th gear: 14.5 mph/23.33 kph

### ADDITIONAL STANDARD EQUIPMENT

- oil cooler for differential and transmission

- two stage air cleaner

- windshield wiper and washer

- fire extinguishers (2 x 5lb)

- horn and back-up alarm

- tool box and tools: track jacks, road arm lifter,

slide hammer and pin punch

- operator/service manual and parts books

### LIGHTING OPTIONS

Basic - 2 Front and 2 Rear

Deluxe - 6 Front and 6 Rear

### ADDITIONAL OPTIONAL EQUIPMENT

AM-FM cassette stereo

Air conditioning, or cab pressurizer

High output heater - 20,500 BTU

### WINCH OPTIONS (not available for Swing Grapple)

Lufkin WD413 40,000lb

John Deere Model 40 or 60 40,000lb or 60,000lb

### DIMENSIONS

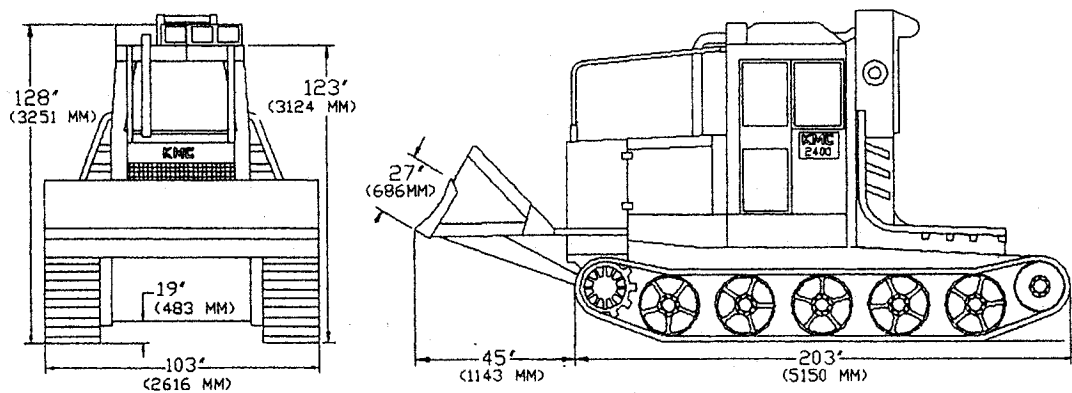

MODEL: 2400 CHOKER ARCH

FOR MORE  
 INFORMATION  
 CONTACT  
 YOUR LOCAL  
 DEALER